

ConTempo 150-250-350

RVP350 HPI-T400W IC 230V-50Hz S SP



MASTER HPI-T Plus - 400 W - Symmetrical

The Contempo floodlight has a registered design that blends well with contemporary outdoor environments. It has a rugged pressure die-casted aluminum housing with corrosion resistant powder coating. Contempo also features an integrated energy saving copper ballast, electronic semi-parallel ignitor and capacitor. The unit has passed rigorous tests for dust and water ingress protection.

Product data

• General Information

Number of light sources	1 pc
Lamp family code	HPI-TP
Lamp power	400 W
Cap-Base	E40 [E40]
Kombipack	-
Compensation circuit	Inductive parallel compensated
Gear	CONV
Country version	NO
Optic type outdoor	Symmetrical
Product family code	RVP350

• Operating and Electrical

Maximum lamp power	-
Input Voltage	230 V
Input Frequency	50 Hz
Ignitor	Semi-parallel

• Approval and Application

Ingress protection code	IP65 [Dust penetration-protected, jet-proof]
-------------------------	---

• Product Data

Full product code	911401044580
Order product name	RVP350 HPI-T400W IC 230V-50Hz S SP
EAN/UPC - Product	6923828620479
Order code	911401044580
Numerator - Quantity Per Pack	1
Numerator - Packs per outer box	1
Material Nr. (12NC)	911401044580
Net Weight (Piece)	10.199 kg

IP65

PHILIPS

Dimensional drawing

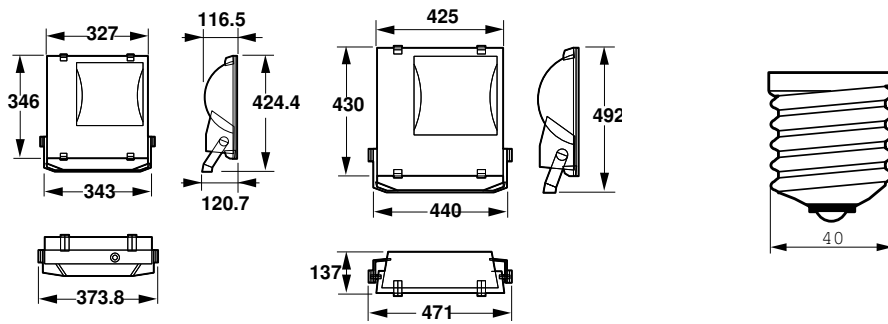

© 2015 Philips Lighting Holding B.V.
All rights reserved.

Specifications are subject to change without notice. Trademarks are the property of Koninklijke Philips N.V. (Royal Philips) or their respective owners.

www.philips.com/lighting

2015, December 24
data subject to change